



## GARDNER-DENVER®

### 7 Series

**Capacity:**  
275 lbs.  
125 kg

- **Compact, Lightweight Design** makes the 7 series the ideal portable, plug-n-go hoists.
- **Self-Cooling, Self-Adjusting Disc Brake** provides smooth stops and starts through 8 ft. of lift.
- **Conveniently Positioned Thumb Controls** allow right or left hand operation.

The smooth running Gardner-Denver 7 series hoists feature a built-in chain container and load capacity up to 275 lbs., making this lightweight (only 24 lbs), compact hoist the perfect solution for an endless number of light duty, low lift height applications. Often found on loading docks, in shipping or receiving areas, or mounted above parts washers or tooling fixtures, this simple to use, portable hoist provides an economical solution for increasing worker productivity.

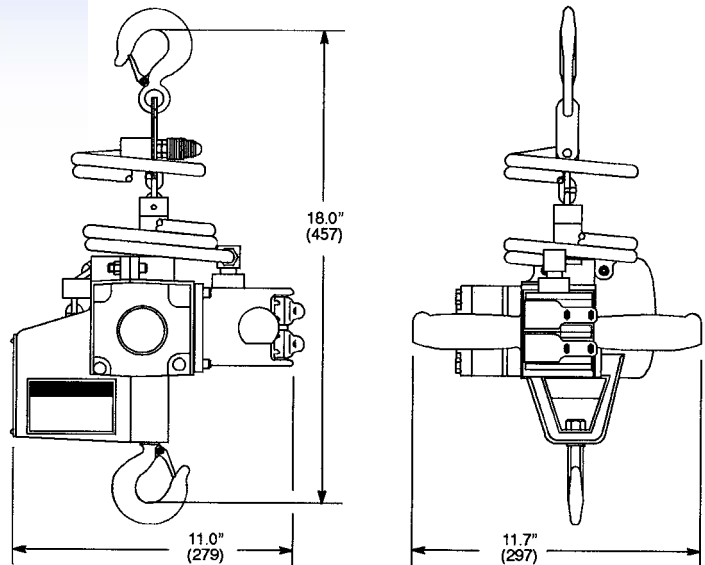

Model Number	Chain Type	Capacity		Lifting & Lowering Speeds				Lift Distance		Weight	
				Maximum Lift		Maximum Lower		ft	m	lbs.	kg
Unit Mounted Control		lbs.	kg	fpm	mpm	fpm	mpm				
75250AC5	LINK	275	125	38	12	60	18	8.0	2.4	24	11

#### GENERAL:

Air Inlet: 3/8" NPT (use 1/2" I.D. Hose)  
Performance rated at 90 psig (6 bar/620 kPa).  
Air Consumption 40 cfm (1.13m<sup>3</sup>/min.) at rated load.

#### STANDARD EQUIPMENT:

Hook mounted air hoist with built-in chain container

#### EXTRA EQUIPMENT:

Trolley – page 20  
Air strainer intake fitting – A9P1450