

Hook Mounted Hoists

GARDNER-DENVER®

P1 Series

Capacity:
300-2000 lbs.
136-907 kg

- Axial Piston Air Motor
- Rope or Pendant Control
- Link or Roller Chain



Single Reeved
300 lbs. (136 kg), 500 lbs. (227 kg) &
1000 lbs. (454 kg) Capacity

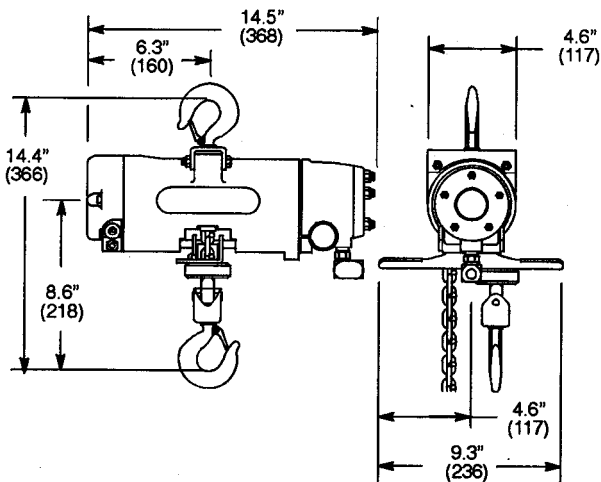

Double Reeved
2000 lbs. (907 kg) Capacity

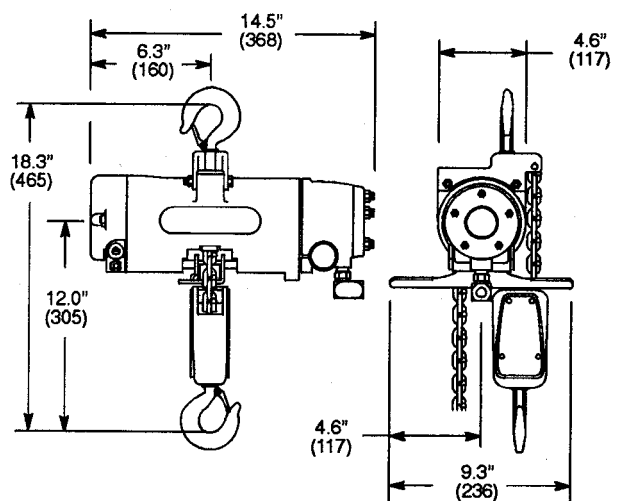

Hook Mounted Hoists

P1	H	A	03	L	P	E	L	---	A	A	A	03
-----------	----------	----------	-----------	----------	----------	----------	----------	------------	----------	----------	----------	-----------

SERIES
P1

TYPE MOUNT
H = Hook

FEATURES
A = Standard Unit
H = Hi Temp Grease
P = Epoxy Paint
S = Epoxy Paint/Hi Temp Grease

CAPACITY
03 = 300 lbs. 09 = *1000 lbs.
04 = *500 lbs. 10 = 1000 lbs.
05 = 500 lbs. 20 = 2000 lbs *Spark Resistant

CHAIN TYPE
L = Link
R = Roller

CONTROL TYPE
P = Pendent (Standard-2LVR)
R = Rope
T = No Control Type (Rope Ready)
W = None-Pendent Ready

CONTROL LENGTH
J = 10 FT Y = 25 FT
O = 15 FT Z = No Control Length
T = 20 FT

CHAIN OPTIONS
L = Standard Link
N = Spark Resistant Roller
P = Zinc Plated Link
R = Standard Roller
X = No Chain

CAPACITY RATING
03 = 300 lbs. (03/04/05/09/10)
05 = 500 lbs. (04/05/09/10)
10 = 1000 lbs. (09/10)
11 = 1000 lbs. (20)
15 = 1500 lbs. (20)
20 = 2000 lbs. (20)

VINTAGE
A

LOWER HOOK
A = Standard (03/05/10)
B = Bullard (03/05/10)
C = S.R. Standard Roller (04/09)
D = S.R. Bullard Roller (04/09)
E = Standard Roller w/mod. lift (03/05/10)
F = Bullard Roller w/10ft. lift (03/05/10)
G = Standard Roller w/10ft. lift (03/05/10)
H = Standard Link (20)
I = Bullard Link (20)
P = Bullard Roller w/mod. lift (03/05/10)
X = No Lower Hook

UPPER HOOK
A = Standard (03/05/10)
B = Bullard (03/05/10)
C = S.R. Standard (04/09)
D = S.R. Bullard (04/09)
E = Standard (20)
F = Bullard (20)
X = No Upper Hook

AMOUNT OF LIFT
--- Specify Length in Feet, 3 digits
Example: 10' lift 010

Note: Numbers in parentheses following an option, represent the hoist capacities for which that option is available.

Model Number		Chain Type	Capacity		Lifting & Lowering Speeds				Reeves	Weight	
					Lifting		Lowering				
Pendent Control	Rope Control		lbs.	kg	fpm	mpm	fpm	mpm		lbs.	kg
P1HA03LPEL010AAA03	P1HA03LREL010AAA03	Link	300	136	80	24	88	27	1	28	13
P1HA03RPER010AGA03	P1HA03RRER010AGA03	Roller	300	136	80	24	88	27	1	28	13
P1HA05LPEL010AAA05	P1HA05LREL010AAA05	Link	500	227	47	14	115	35	1	28	13
P1HA05RPER010AGA05	P1HA05RRER010AGA05	Roller	500	227	47	14	115	35	1	28	13
P1HA10LPEL010AAA10	P1HA10LREL010AAA10	Link	1000	454	19	6	49	15	1	28	13
P1HA10RPER010AGA10	P1HA10RRER010AGA10	Roller	1000	454	19	6	49	15	1	28	13
P1HA20LPEL010EHA20	P1HA20LREL010EHA20	Link	2000	907	9.5	3	24	7	2	31	14
Spark Resistant Units											
P1HA04RPEN010CCA05	P1HA04RREN010CCA05	Roller	500	227	47	14	115	35	1	28	13
P1HA09RPEN010CCA10	P1HA09RREN010CCA10	Roller	1000	454	19	6	49	15	2	28	13

GENERAL:
Air Inlet: 3/8" NPT (use 1/2" I.D. Hose)
Performance rated at 90 psig (6 bar/620 kPa) air pressure.
Air Consumption 25 cfm (.71 m³/min.) at rated load.

STANDARD EQUIPMENT:
Hook mounted air hoist with 10 ft. (3.0m) lift
Rope Control: 5 ft. (1.5m) rope length
Pendent Control: 5 ft. (1.5m) hose length

EXTRA EQUIPMENT:
Chain container – pages 52-53
Hoist trolleys – page 20
Auxiliary cable (Backup suspension) – page 55
Piped exhaust adapter (1/2"NPT) – 500344