

Trolleys for Lug Mounted Hoists

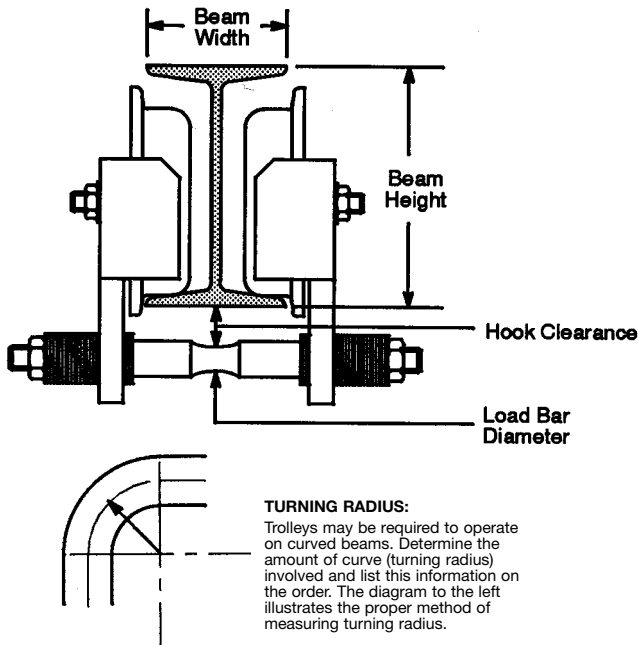

Hoist Capacity		Beam Width				Minimum Radius Turning		Part Number			Hook Clearance**		Load Bar Diameter	
		Min.		Max.				Taper Wheel	Flat Wheel	Drawbar*	in.	mm	in.	mm
lbs.	kg	in.	mm	in.	mm	in.	mm				in.	mm	in.	mm

Hoist Series K5

550	250	2.66	68	4.66	118	18	457	534925	•534926	A60165	1.88	48	0.88	22
1100	500	2.66	68	4.66	118	18	457	527431	•528235	A60165	1.88	48	0.88	22
2200	1000	3.00	76	5.25	133	21	533	527432	•528236	A60164	2.25	57	1.12	28

Hoist Series P1

300	136	2.66	68	4.66	118	18	457	•539383	•539384	A60165	1.88	48	0.88	22
500	227	2.66	68	4.66	118	18	457	534923	•534924	A60165	1.88	48	0.88	22
1000	454	2.66	68	4.66	118	18	457	527491	528161	A60165	1.88	48	0.88	22
2000	908	3.00	76	5.25	133	21	533	527492	•528166	A60164	2.25	57	1.12	28

*NOTE: Drawbar for Hoistractor

NOTE: Dimensions are for smallest size track

NOTE: • Available on quotation basis only.