

Trolley Mounted Hoists

GARDNER-DENVER®

K5 Series

Capacity:
550-2200 lbs.
250-1000 kg

Beam flange width:
3.0-6.0 in
76-162 mm

Minimum turning radius:
34 in
864 mm

- Rotary Vane Air Motor
- Rope or Pendant Control
- Link Chain



Single Reeved
5500 lbs. (250 kg) & 1100 lbs. (500 kg) Capacity

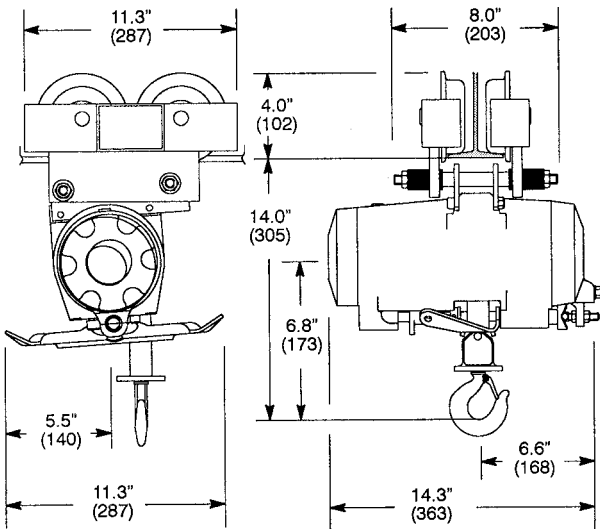

Double Reeved
2200 lbs. (1000 kg) Capacity

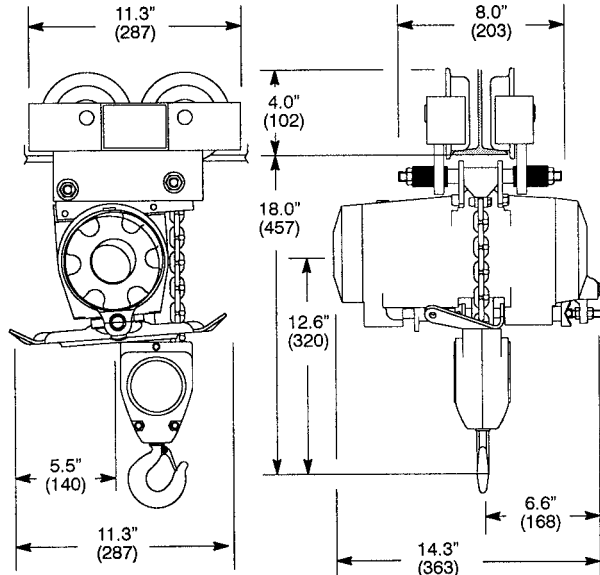

Trolley Mounted Hoists

K5 T A 05 L P E L --- A A A 05

SERIES

K5

TYPE MOUNT

T = Trolley

FEATURES

- A = Standard Unit
- H = Hi Temp Grease
- P = Epoxy Paint
- S = Epoxy Paint/Hi Temp Grease

CAPACITY

- 05 = 550 lbs.
- 11 = 1100 lbs.
- 22 = 2200 lbs.

CHAIN TYPE

L = Link

CONTROL TYPE

- P = Pendent (Standard-2LVR)
- R = Rope
- W = None-Pendent Ready
- X = None

CONTROL LENGTH

- E = 5 FT
- J = 10 FT
- O = 15 FT
- T = 20 FT
- Y = 25 FT
- Z = No Control Length

CHAIN TYPE

- L = Standard Link
- P = Zinc Plated Link
- X = No Chain

CAPACITY RATING

- 05 = 550 lbs. (05/11)
- 06 = 550 lbs. (22)
- 11 = 1100 lbs. (11)
- 12 = 1100 lbs. (22)
- 22 = 2200 lbs. (22)

VINTAGE

A

LOWER HOOK

- A = Standard Link (05/11)
- B = Bullard Link (05/11)
- C = Standard Link (22)
- D = Bullard Link (22)
- X = No Hook

TROLLEY

- A = 3-5" Tapered for (05/11/22)
- B = 5-6" Tapered for (05/11/22)
- C = 3-5" Tapered w/Hoistractor bracket (05/11/22)
- D = 5-6" Flat for (05/11/22)
- E = 3-5" Flat for (05/11/22)
- F = 3-5" Flat w/Hoistractor bracket (05/11/22)
- G = 2" Nr w Flat for (05/11/22)
- H = 2" Nr w Flat w/Hoistractor bracket (05/11/22)

AMOUNT OF LIFT

Specify Length in Feet, 3 digits
Example: 10' lift 010

Note: Numbers in parentheses following an option, represent the hoist capacities for which that option is available.

Model Number		Chain Type	Capacity		Lifting & Lowering Speeds				Reeves	Weight	
Pendent Control	Rope Control		lbs.	kg	Maximum Lift		Maximum Lower			lbs.	kg
					fpm	mpm	fpm	mpm			
K5TA05LPEL010AAA05	K5TA05LREL010AAA05	Link	550	250	40-67	12-20	110-147	33-44	1	82	37
K5TA11LPEL010AAA11	K5TA11LREL010AAA11	Link	1100	500	20-50	6-15	80-120	24-36	1	82	37
K5TA22LPEL010ACA22	K5TA22LREL010ACA22	Link	2200	1000	10-25	3-7	40-60	12-18	2	93	42

GENERAL:

Air Inlet: 1/2" NPT (use 3/4" I.D. Hose)
Performance rated at 90 psig (6 bar/620 kPa) air pressure.
Air Consumption 75 cfm (2.12 m³/min.) at rated load.

STANDARD EQUIPMENT:

Trolley mounted air hoist with 10 ft. (3.0m) lift
Tapered Wheels
Rope Control: 5 ft. (1.5m) rope length
Pendent Control: 5 ft. (1.5m) hose length

EXTRA EQUIPMENT:

Chain container – page 53
Air strainer intake fitting – A10161
Piped exhaust adapter (3/4"NPT) – 536567
Tractor connection kit – 530388 (Used to modify existing Hoist)