

Trolley Mounted Hoists

GARDNER-DENVER®

K1 Series

Capacity:
2200-8800 lbs.
1000-4000 kg

Beam flange width:
2200 lbs., 3300 lbs., 4400 lbs. capacity
3.00-6.25 in
76-159 mm

6600 lbs., 8800 capacity
4.00-6.25 in
102-159 mm

Minimum turning radius:
2200 lbs., 3300 lbs., 4400 lbs. capacity
60 in
1524 mm

6600 lbs., 8800 lbs. capacity
72 in
1829 mm

- Rotary Vane Air Motor
- Rope or Pendant Control
- Link Chain



Single Reeved
2200 lbs. (1000 kg), 3300 lbs. (1500 kg) &
4400 lbs. (2000 kg) Capacity

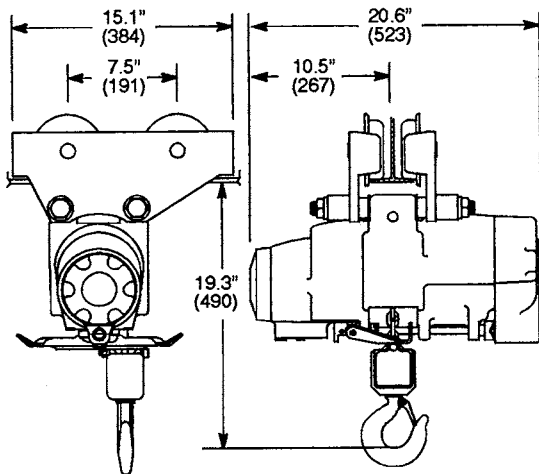

Double Reeved
6600 lbs. (3000 kg) & 8800 lbs. (4000 kg) Capacity

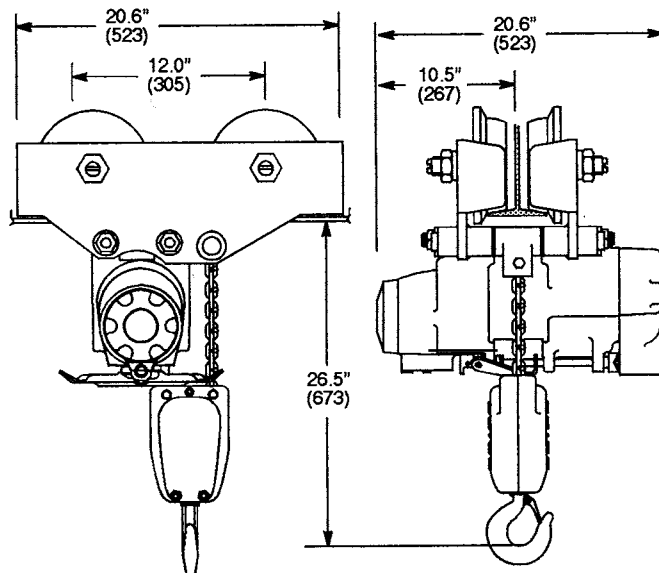

Trolley Mounted Hoists

K1 T A 22 L P E P --- A A A 22

SERIES

K1

TYPE MOUNT

T = Trolley

FEATURES

A = Standard Unit
 H = Hi Temp Grease
 P = Epoxy Paint
 S = Epoxy Paint/Hi Temp Grease

CAPACITY

22 = 2200 lbs. 66 = 6600 lbs.
 33 = 3300 lbs. 88 = 8800 lbs.
 44 = 4400 lbs.

CHAIN TYPE

L = Link

CONTROL TYPE

P = Pendent (Standard-2LVR)
 R = Rope
 W = None-Pendent Ready
 X = None

CONTROL LENGTH

E = 5 FT T = 20 FT
 J = 10 FT Y = 25 FT
 O = 15 FT Z = No Control Length

CHAIN OPTIONS

L = Standard Link
 P = Zinc Plated Link
 X = No Chain

CAPACITY RATING

11 = 1100 lbs. (22/33/44)
 22 = 2200 lbs. (22/33/44)
 33 = 3300 lbs. (33/44)
 34 = 3300 lbs. (66)
 44 = 4400 lbs. (44)
 45 = 4400 lbs. (66/88)
 66 = 6600 lbs. (66)
 88 = 8800 lbs. (88)

VINTAGE

A

LOWER HOOK

A = Standard Link (22/33/44)
 B = Bullard Link (22/33/44)
 C = Standard Link (66/88)
 D = Bullard Link (66/88)
 X = No Hook

TROLLEY

A = 3-6.25" Tapered (22/33/44)
 B = 4-6.25" Tapered (66/88)
 C = 3.25" NrW Flat (66/88)
 D = 3-6.25" Flat (22/33/44)
 E = 4-6.25" Flat (66/88)
 F = 2" NrW Flat (22/33/44)

AMOUNT OF LIFT

Specify Length in Feet, 3 digits
 Example: 10' lift 010

Note: Numbers in parentheses following an option, represent the hoist capacities for which that option is available.

Model Number		Chain Type	Capacity		Lifting & Lowering Speeds				Reeves	Weight	
Pendent Control	Rope Control		lbs.	kg	Maximum Lift		Maximum Lower			lbs.	kg
					fpm	mpm	fpm	mpm			
K1TA22LPEP010AAA22	K1TA22LREP010AAA22	Link	2200	1000	33	10	52	16	1	270	123
K1TA33LPEP010AAA33	K1TA33LREP010AAA33	Link	3300	1500	21	6	34	10	1	270	123
K1TA44LPEP010AAA44	K1TA44LREP010AAA44	Link	4400	2000	15	5	24	7	1	270	123
K1TA66LPEP010BCA66	K1TA66LREP010BCA66	Link	6600	3000	10	3	17	5	2	278	140
K1TA88LPEP010BCA88	K1TA88LREP010BCA88	Link	8800	4000	7	2	12	4	2	278	140

GENERAL:

Air Inlet: 1/2" NPT (use 3/4" I.D. Hose)
 Performance rated at 90 psig (6 bar/620 kPa) air pressure.
 Air Consumption 75 cfm (2.12 m³/min.) at rated load.

STANDARD EQUIPMENT:

Trolley mounted air hoist with 10 ft. (3.0m) lift
 Tapered Wheels
 Rope Control: 5 ft. (1.5m) rope length
 Pendent Control: 5 ft. (1.5m) hose length

EXTRA EQUIPMENT:

Chain container – page 53
 Piped exhaust adapter (3/4"NPT) – 536567
 Tractor connection kit – 516710 (Used to modify existing Hoist)