

# Trolley Mounted Hoists

## GARDNER-DENVER®

### P1 Series

Capacity:  
300-1000 lbs.  
136-454 kg

Beam flange width:  
2.63-5.00 in  
67-127 mm

Minimum turning radius:  
26 in  
660 mm

- Axial Piston Air Motor
- Rope or Pendant Control
- Link Chain



#### Single Reeved

300 lbs. (136 kg), 500 lbs. (227 kg) & 1000 lbs. (454 kg) Capacity

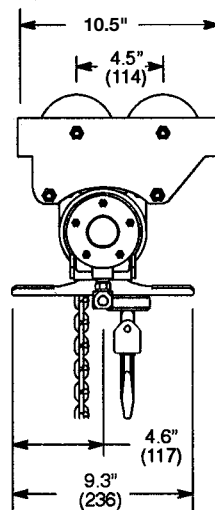
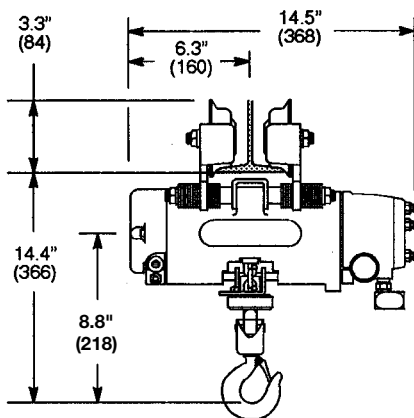

# Trolley Mounted Hoists

**P1 T A 05 L P E L --- A A A 05**

**SERIES**

P1

**TYPE MOUNT**

T = Trolley

**FEATURES**

- A = Standard Unit
- H = Hi Temp Grease
- P = Epoxy Paint
- S = Epoxy Paint/Hi Temp Grease

**CAPACITY**

- 03 = 300 lbs.
- 05 = 500 lbs.
- 10 = 1000 lbs.

**CHAIN TYPE**

L = Link

**CONTROL TYPE**

- P = Pendant (Standard-2LVR)
- R = Rope
- W = None-Pendent Ready
- T = No Control Type (Rope Ready)

**CONTROL LENGTH**

- E = 5 FT
- J = 10 FT
- O = 15 FT
- T = 20 FT
- Y = 25 FT
- Z = No Control Length

**CHAIN OPTIONS**

- L = Standard Link
- P = Zinc Plated Link
- X = No Chain

**CAPACITY RATING**

- 03 = 300 lbs. (03/05/10)
- 05 = 500 lbs. (05/10)
- 10 = 1000 lbs. (10)

**VINTAGE**

A

**LOWER HOOK**

- A = Standard (03/05/10)
- B = Bullard (03/05/10)
- X = No Hook

**TROLLEY**

- A = 2.63-5" Tapered (03/05/10) (standard)
- B = 5-7" Tapered (03/05/10)
- C = 2.63-5" Tapered w/Hoistractor bracket (03/05/10)
- D = 5-7" Flat (03/05/10)
- E = 2.63-5" Flat (03/05/10)
- F = 2.63-5" Flat w/Hoistractor bracket (03/05/10)
- G = 2" Nrwr Flat (03/05/10)
- H = 2" Nrwr Flat w/Hoistractor bracket (03/05/10)

**AMOUNT OF LIFT**

Specify Length in Feet, 3 digits

Example: 10' lift 010

Note: Numbers in parentheses following an option, represent the hoist capacities for which that option is available.

Model Number		Chain Type	Capacity		Lifting & Lowering Speeds				Reeves	Weight	
Pendent Control	Rope Control		lbs.	kg	Lifting		Lowering			lbs.	kg
						fpm	mpm	fpm	mpm		
P1TA03LPEL010AAA03	P1TA03LREL010AAA03	Link	300	136	80	24	88	27	1	50	23
P1TA05LPEL010AAA05	P1TA05LREL010AAA05	Link	500	227	47	14	115	35	1	50	23
P1TA10LPEL010AAA10	P1TA10LREL010AAA10	Link	1000	454	19	6	49	15	1	50	23

**GENERAL:**

Air Inlet: 3/8" NPT (use 1/2" I.D. Hose)  
 Performance rated at 90 psig (6 bar/620 kPa) air pressure.  
 Air Consumption 25 cfm (.71 m<sup>3</sup>/min.) at rated load.

**STANDARD EQUIPMENT:**

Trolley mounted air hoist with 10 ft. (3.0m) lift  
 Tapered Wheels  
 Rope Control: 5 ft. (1.5m) rope length  
 Pendant Control: 5 ft. (1.5m) hose length

**EXTRA EQUIPMENT:**

Chain container – page 53  
 Piped exhaust adapter (1/2"NPT) – 500344  
 Tractor connection kit – 502953 (Used to modify existing Hoist)