

Trolley Mounted Hoists

GARDNER-DENVER®

P2 Series

Capacity:
1100-4400 lbs.
500-2000 kg

Beam flange width:
3.00-5.00 in
76-127 mm

Minimum turning radius:
1000 lbs., 1100 lbs., 1500 lbs.,
2200 lbs. capacity
36 in
914 mm

3000 lbs., 4400 lbs. capacity
60 in
1524 mm

- Axial Piston Air Motor
- Rope or Pendent Control
- Link Chain



Single Reeved
1100 lbs. (500 kg), 1500 lbs. (680 kg) &
2200 lbs. (1000 kg) Capacity

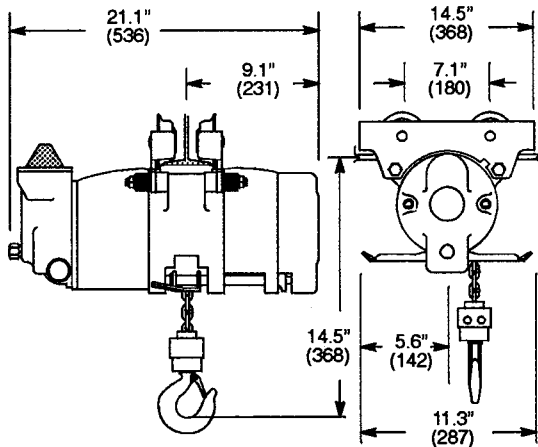

Double Reeved
3000 lbs. (1360 kg) & 4400 lbs. (2000 kg) Capacity

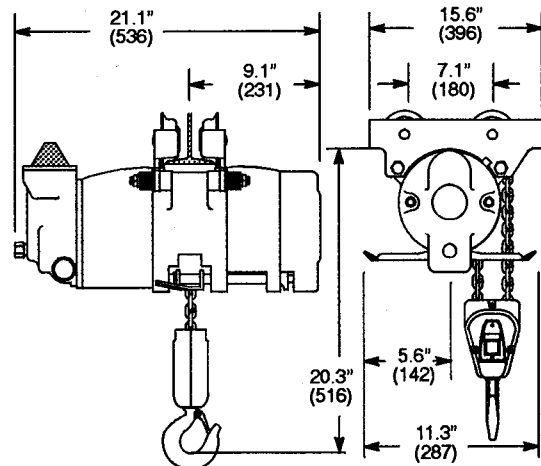

Trolley Mounted Hoists

P2 T A 11 L P E L --- A A A 11

SERIES

P2

TYPE MOUNT

T = Trolley

FEATURES

- A = Standard Unit
- E = Edible Grease
- H = Hi Temp Grease
- P = Epoxy Paint
- R = Epoxy Paint/Edible Grease
- S = Epoxy Paint/Hi Temp Grease

CAPACITY

- 10 = 1000 lbs.
 - 11 = 1100 lbs.
 - 15 = *1500 lbs.
 - 22 = 2200 lbs.
 - 30 = *3000 lbs.
 - 44 = 4400 lbs.
- *Spark Resistant

CHAIN TYPE

L = Link

CONTROL TYPE

- P = Pendent (Standard-2LVR)
- R = Rope
- W = None-Pendent Ready
- T = No Control (Rope Ready)

CONTROL LENGTH

- E = 5 FT
- J = 10 FT
- O = 15 FT
- T = 20 FT
- Y = 25 FT
- Z = No Control Length

CHAIN OPTIONS

- L = Standard Link
- P = Zinc Plated Link
- Q = S.R. Link
- X = No Chain

Note: Numbers in parentheses following an option, represent the hoist capacities for which that option is available.

CAPACITY RATING

- 03= 300 lbs. (10/11/15)
- 05= 300 lbs. (10/11/15)
- 10= 1000 lbs. (10/11/15)
- 11= 1100 lbs. (11/15/22)
- 15= 1500 lbs. (15/22)
- 20= 2000 lbs. (22)
- 22= 2200 lbs. (22)
- 30= 3000 lbs. (30/44)
- 31= 1100 lbs. (30)
- 32= 2200 lbs. (30/44)
- 40= 4000 lbs. (44)
- 44= 4400 lbs. (44)

VINTAGE

A

LOWER HOOK

- A = Standard (11/22)
- B = Bullard (11/22)
- C = S.R. Std. (10/15)
- D = S.R. Bullard (10/15)
- E = S.R. Std. (30)
- F = S.R. Bullard (30)
- G = Standard (44)
- H = Bullard (44)
- X = No Hook

TROLLEY

- A = 3-5" Tapered (11/22)
- B = 3-5" Tapered S.R. (10/15)
- C = 3-5" Tapered S.R. (30)
- D = 3-5" Tapered (44)
- E = 3-5" Flat (11/22)
- F = 3-5" Flat S.R. (10/15)
- G = 3-5" Flat S.R. (30)
- H = 3-5" Flat (44)
- I = 2" NrW Flat (11/22)
- J = 2" NrW Flat S.R. (10/15)
- K = 2" NrW Flat S.R. (30)
- L = 2" NrW Flat (44)
- M = 5-7" Tapered (11/22)
- N = 5-7" Tapered (44)
- O = 5-7" Tapered S.R. (10/15)
- P = 5-7" Tapered S.R. (30)
- Q = 5-7" Flat (11/22)
- R = 5-7" Flat (44)
- S = 5-7" Flat S.R. (10/15)
- T = 5-7" Flat S.R. (30)

AMOUNT OF LIFT

--- Specify Length in Feet, 3 digits
Example: 10' lift 010

Model Number		Chain Type	Capacity		Lifting & Lowering Speeds				Reeves	Weight	
Pendent Control	Rope Control		lbs.	kg	Maximum Lift	Maximum Lower	fpm	mpm		lbs.	kg
P2TA11LPEL010AAA11	P2TA11LREL010AAA11	Link	1100	500	34	10	107	33	1	113	51
P2TA22LPEL010AAA22	P2TA22LREL010AAA22	Link	2200	1000	17	5	56	17	1	113	51
P2TA44LPEL010DGA44	P2TA44LREL010DGA44	Link	4400	2000	9	3	28	9	2	145	66
Spark Resistant Units											
P2TA10LPEQ010BCA10	P2TA10LREQ010BCA10	Link	1000	454	38	12	107	33	1	113	51
P2TA15LPEQ010BCA15	P2TA15LREQ010BCA15	Link	1500	680	23	7	58	18	1	113	51
P2TA30LPEQ010CEA30	P2TA30LREQ010CEA30	Link	3000	1360	11	3	26	8	2	145	66

GENERAL:

Air Inlet: 3/8" NPT (use 1/2" I.D. Hose)
Performance rated at 90 psig (6 bar/620 kPa) air pressure.
Air Consumption 44 cfm (1.2 m³/min.) at rated load.

STANDARD EQUIPMENT:

Trolley mounted air hoist with 10 ft. (3.0m) lift
Tapered Wheels
Rope Control: 5 ft. (1.5m) rope length
Pendent Control: 5 ft. (1.5m) hose length

EXTRA EQUIPMENT:

Modified lift length (specify when ordering)
Chain container – page 53
Piped exhaust adapter (3/4"NPT) – 535779
Tractor connection kit: (Used to modify existing Hoist)
(1100, 1500, 2200 cap.) – 534919
(3000, 4400 cap.) – 534920