

Trolley Mounted Hoists

GARDNER-DENVER®

P3 Series

Capacity:
2200-8000 lbs.
1000-3629 kg

Beam flange width:
2200 lbs., 4300 lbs. capacity
3.38-6.25 in
86-159 mm

8000 lbs. capacity
4.00-6.25 in
102-159 mm

Minimum turning radius:
2200 lbs., 4300 lbs. capacity
60 in
1524 mm

8000 lbs. capacity
72 in
1829 mm

- Axial Piston Air Motor
- Pendant Control
- Link Chain



Single Reeved
2200 lbs. (1000 kg) & 4300 lbs. (1950 kg) Capacity

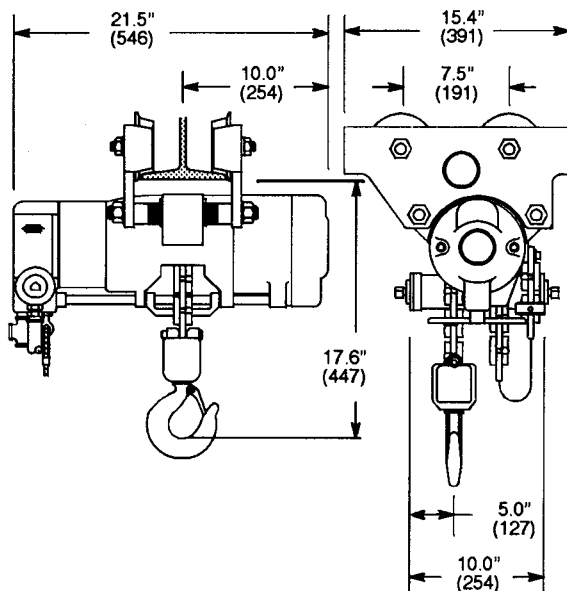

Double Reeved
8000 lbs. (3629 kg) Capacity

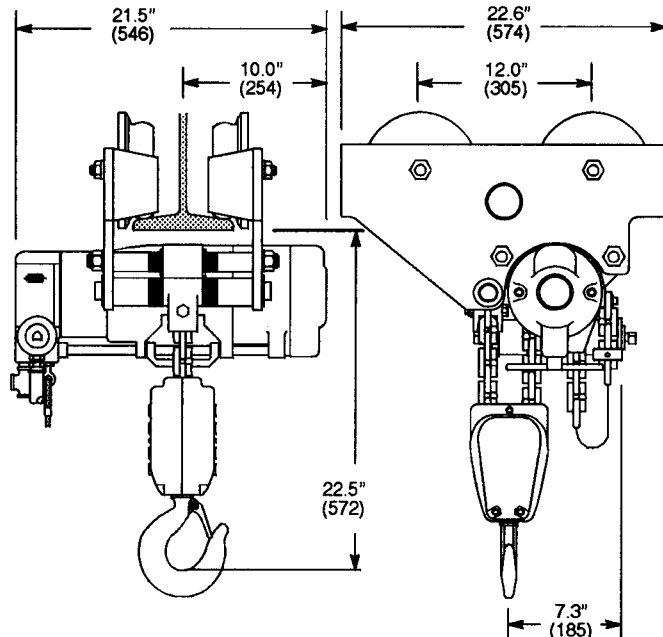

Trolley Mount Hoists

P3 T A 22 L P E P --- A A A 22

SERIES

P3

TYPE MOUNT

T = Trolley

FEATURES

A = Standard Unit
 H = Hi Temp Grease
 P = Epoxy Paint
 S = Epoxy Paint/Hi Temp Grease

CAPACITY

22 = 2200 lbs.
 43 = 4300 lbs.
 80 = 8000 lbs.

CHAIN TYPE

L = Link

CONTROL TYPE

P = Pendant Standard (2LVR)
 X = None-Pendant Ready

CONTROL LENGTH

E = 5 FT T = 20 FT
 J = 10 FT Y = 25 FT
 O = 15 FT Z = No Control Length

CHAIN OPTIONS

L = Standard Link
 P = Zinc Plated Link
 X = No Chain

CAPACITY RATING

11 = 1100 lbs. (22)
 20 = 2000 lbs. (22/43)
 22 = 2200 lbs. (22/43)
 40 = 4000 lbs. (43)
 43 = 4300 lbs. (43)
 50 = 5000 lbs. (80)
 60 = 6000 lbs. (80)
 80 = 8000 lbs. (80)

VINTAGE

A

LOWER HOOK

A = Standard (22/43)
 B = Bullard (22/43)
 C = Standard (80)
 D = Bullard (80)
 X = No Hook

TROLLEY

A = 3.38-6.25" Tapered (22/43)
 B = 4-6.25" Tapered (80)
 C = 3.25-3.33" Nrw Flat (80)
 D = 3.38-6.25" Flat (22/43)
 E = 4-6.25" Flat (80)

AMOUNT OF LIFT

--- Specify Length in Feet, 3 digits
 Example: 10' lift 010

Note: Numbers in parentheses following an option, represent the hoist capacities for which that option is available.

Model Number	Chain Type	Capacity		Lifting & Lowering Speeds				Reeves	Weight	
				Maximum Lift		Maximum Lower				
		lbs.	kg	fpm	mpm	fpm	mpm		lbs.	kg
P3TA22LPEP010AAA22	Link	2200	1000	30	9	80	24	1	270	123
P3TA43LPEP010AAA43	Link	4300	1950	15	5	40	12	1	270	123
P3TA80LPEP010BCA80	Link	8000	3629	7	2	20	6	2	335	152

GENERAL:

Air Inlet: 1/2" NPT (use 3/4" I.D. Hose)
 Performance rated at 90 psig (6 bar/620 kPa) air pressure.
 Air Consumption 83 cfm (2.35 m³/min.) at rated load.

STANDARD EQUIPMENT:

Trolley mounted air hoist with 10 ft. (3.0m) lift
 Tapered Wheels
 Pendant Control: 5 ft. (1.5m) hose length

EXTRA EQUIPMENT:

Chain container – page 53