

Hoist/Hoist tractor Combination (Low Headroom)

GARDNER-DENVER® P3 Series

Capacity:
2200-4300 lbs.
1000-1950 kg

Beam flange width:
3.00 - 4.00 in
76 - 102 mm

Minimum turning radius:
60 in
1524 mm

- Axial Piston Air Motor
- Pendant Control
- Link Chain

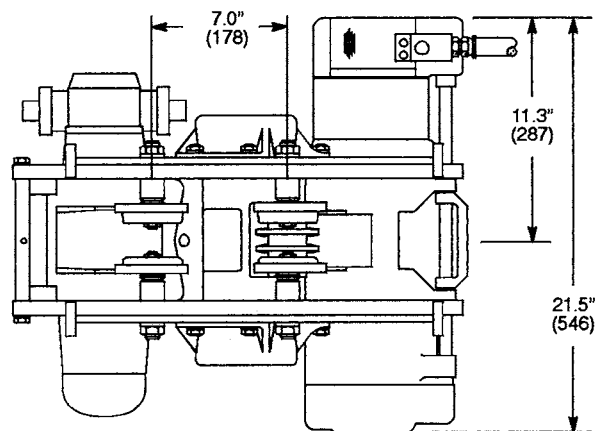
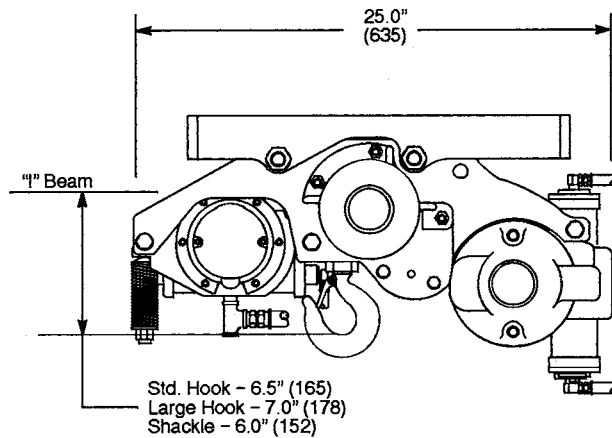

Hoist/Hoistactor Combination (Low Headroom)

P3	N	A	22	L	P	E	P	010	A	A	A	22
-----------	----------	----------	-----------	----------	----------	----------	----------	------------	----------	----------	----------	-----------

SERIES
P3

TYPE MOUNT
N = Combination Unit (Low Headroom)

FEATURES
A = Standard Unit
H = Hi Temp Grease
P = Epoxy Paint
S = Epoxy Paint/Hi Temp Grease

CAPACITY
22 = 2200 lbs.
43 = 4300 lbs.

CHAIN TYPE
L = Link

CONTROL TYPE
P = Pendent Standard

CONTROL LENGTH

E = 5 FT	T = 20 FT
J = 10 FT	X = 24 FT
O = 15 FT	Z = No Control Length

CHAIN OPTIONS
P = Zinc Plated Link

CAPACITY RATING
10 = 1000 lbs. (22)
15 = 1500 lbs. (22)
20 = 2000 lbs. (22/43)
22 = 2200 lbs. (22/43)
40 = 4000 lbs. (43)
43 = 4300 lbs. (43)

VINTAGE
A

LOWER SUPPORT
A = Std. Hook (1-1/8" opening)
B = Large Hook (1-11/32" opening)
C = Shackle (1-1/6" W x 1" H opening)

TRACTOR/TROLLEY
A = STD SPD/Taper (22/43)
B = STD SPD/Flat (22/43)
D = Slow SPD/Taper (22/43)
E = Slow SPD/Flat (22/43)
G = Hi-Spd. Taper (22/43)
H = Hi-Spd Flat (22/43)
I = STD SPD, Taper (22/43)
J = STD SPD, Flat (22/43)
K = SL SPD, Taper (22/43)
L = Slow SPD, Flat (22/43)
M = Hi Spd., Taper (22/43)
N = Hi Spd, Flat (22/43)

AMOUNT OF LIFT
Specify Length in Feet, 3 digits
Example: 10' Lift 010

Note: Numbers in parentheses following an option, represent the hoist capabilities for which that option is available.

Model Number	Chain Type	Capacity		Lifting & Lowering Speeds				Traversing Speed		Reeves	Weight	
				Maximum Lift		Maximum Lower		fpm	mpm		lbs.	kg
Pendent Control	lbs.	kg	fpm	mpm	fpm	mpm	fpm			mpm		
P3NA22LPEP010AAA22	Link	2200	1000	30	9	80	24	69	21	1	225	102
P3NA43LPEP010AAA43	Link	4300	1950	15	5	40	12	65	20	1	225	102

GENERAL:

Air Inlet: 1/2" NPT (use 3/4" I.D. Hose)
 Performance rated at 90 psig (6 bar/620 kPa) air pressure.
 Air Consumption:
 Hoist – 83 cfm (2.35 m³/min.) at rated load.
 Hoistactor – 30 cfm (.8 m³/min) at rated load.

STANDARD EQUIPMENT:

Hoist/Hoistactor combination unit with 10 ft. (3.0m) lift
 Pendent Control: 5 ft. (1.5m) hose length

EXTRA EQUIPMENT:

Chain container – page 53